

DIGITAL Custom AlphaServer 4100 System in a Rittal Cabinet

Installation Guide

Part Number: EK-410RC-IN. A01

January 1998

**Digital Equipment Corporation
Maynard, Massachusetts**

January 1998

Digital Equipment Corporation makes no representations that the use of its products in the manner described in this publication will not infringe on existing or future patent rights, nor do the descriptions contained in this publication imply the granting of licenses to make, use, or sell equipment or software in accordance with the description.

Possession, use, or copying of the software described in this publication is authorized only pursuant to a valid written license from DIGITAL or an authorized sublicensor.

© Digital Equipment Corporation 1998. All rights reserved.

The following are trademarks of Digital Equipment Corporation: AlphaServer, DIGITAL, StorageWorks, and the DIGITAL logo.

The following are third-party trademarks:
Rittal is a trademark of Rittal Corporation

S3617

Table of Contents

1 Introduction

1.1 General..... 1-1
1.2 Mounting Hardware and Components List..... 1-1

2 Installation

2.1 General..... 2-1
2.2 Unpacking the Shipment..... 2-1
2.3 Installing the Custom AlphaServer 4100 System..... 2-2
 2.3.1 Assembling the Slide Assemblies..... 2-2
 2.3.1.1 Assembling the Right Slide Assembly..... 2-2
 2.3.1.2 Assembling the Left Slide Assembly..... 2-3
 2.3.2 Determining the Installation Area 2-4
 2.3.3 Attaching the Slide Assemblies to the Cabinet Rails 2-6
 2.3.3.1 Attaching the Right Slide Assembly to the Cabinet Rails 2-6
 2.3.3.2 Attaching the Left Slide Assembly to the Cabinet Rails 2-7
 2.3.4 Installing Cage Nuts on the Front Rails..... 2-7
 2.3.5 Attaching the Inner Races to the Chassis..... 2-8
 2.3.6 Mounting the System on the Slides 2-9
 2.3.7 Connecting and Routing the Power Cord(s).....2-10
 2.3.8 Installing the Front Bezel.....2-11
2.4 Installing the Swing Arm Cable Management Bracket.....2-13
2.5 Installing the 2T-EXBAY Options2-14

Figures

Figure 2-1 Attaching the Slide Brackets to the Slide Assemblies 2-3
Figure 2-2 Installation Area and Rail-Hole Pattern (Front View) 2-4
Figure 2-3 Installation Area and Rail Hole Pattern (Rear View) 2-5
Figure 2-4 Attaching the Slide Assemblies to the Cabinet Rails..... 2-6
Figure 2-5 Attaching the Inner Slide Races..... 2-8
Figure 2-6 Mounting the System on the Slides..... 2-9
Figure 2-7 Connecting and Routing the Power Cord(s).....2-10
Figure 2-8 Installing the Front Bezel2-11
Figure 2-9 Securing the System to the Cabinet Rails2-12
Figure 2-10 Installing the Swing Arm Cable Management Bracket.....2-13

Tables

Table 1-1 Mounting Hardware and Component List 1-1

Table 2-1 2T-EXBAY Options 2-14

Preface

Overview

This guide provides the information necessary to install the DIGITAL custom AlphaServer 4100 system in a Rittal cabinet.

Intended Audience

This guide is intended for DIGITAL service personnel or qualified Self-maintenance customers who are familiar with installing computer systems.

Organization

This guide is organized as follows:

Chapter 1, Introduction – Provides an overview of installing the DIGITAL custom AlphaServer 4100 in a Rittal cabinet along with a parts list.

Chapter 2, Upgrade Procedure – Provides the detailed procedures for installing the custom AlphaServer 4100 system in a Rittal cabinet.

Related Documents

Other documents related to the DIGITAL custom AlphaServer 4100 system include the following:

- *DIGITAL Custom AlphaServer 4100 System Solutions Installation/Owner's/Service Guide* (EK-410LP-IN)

Conventions

This guide uses the following conventions:

Convention	Meaning
Note	A note calls the reader's attention to any item of information that may be of special importance.
Caution	A caution contains information essential to avoid damage to the equipment.
Warning	A warning contains information essential to the safety of personnel.
❶	Circled numbers provide a link between figures or examples and text.
<i>Italic type</i>	Italic type emphasizes important information, indicates variables, and indicates complete titles of manuals.

The following symbols appear on the chassis. Please review their definitions below:



This Dangerous Voltage warning symbol indicates risk of electrical shock and indicates hazards from dangerous voltage.



This Attention symbol is used to alert the reader about specific safety conditions, and to instruct the reader to read separate instructional material.

Reader's Comments

DIGITAL welcomes your comments on this or any other manual. You can send your comments to DIGITAL by mail to the following address:

Digital Equipment Corporation
Shared Engineering Services
PKO3-2/21J
129 Parker Street
Maynard, MA 01754-2199

Introduction

1.1 General

This chapter contains an overview of installing the DIGITAL custom AlphaServer 4100 system in a Rittal cabinet along with a parts list.

The custom AlphaServer 4100 system can be installed in a Rittal cabinet by using mounting hardware that is different from the mounting hardware used for installation in a standard DIGITAL English or metric RETMA cabinet. The main differences include the following:

- Slide mounting brackets
- Installation rail-hole pattern
- The use of Rittal cage nuts
- A swing arm cable management bracket

1.2 Mounting Hardware and Components List

Table 1-1 lists the mounting hardware and components included with the system shipment for installation in a Rittal cabinet.

Table 1-1 Mounting Hardware and Component List

Description	Part Number	Quantity
Chassis slide assembly (pre-assembled with slide mounting brackets)	12-46387-01	1 pair
Slide mounting brackets (LF/LR) (pre-assembled to slide assemblies)	74-53081-01	2
Slide mounting brackets (RF/RR) (pre-assembled to slide assemblies)	74-53082-01	2
M6 screw	90-40333-02	8
Screw, 8-32 pan-head	90-09545-00	8
Front bezel	74-53083-01	1
Screw, 8-32 flat-head	90-00039-01	6
M6 cage nut	90-40333-01	4
Swing arm cable management bracket (cabinet)	12-26281-01	1
Screw, 10-32 truss-head	90-00063-39	4
U-nut	90-07786-00	4
Molded right angle power cord	17-04522-03	1
Strain relief	12-21249-01	1
Tie-wraps	90-07031-01	15
<i>DIGITAL Custom AlphaServer 4100 System in a Rittal Cabinet Installation Guide</i>	EK-410RC-IN	1

2.1 General

This chapter covers the installation of the custom AlphaServer 4100 system in a 43U Rittal cabinet. The major topics covered in this chapter include:

- Unpacking the Shipment
- Installing the Custom AlphaServer 4100 System
 - Assembling the Slide Assemblies
 - Determining the Installation Area
 - Attaching the Slide Assemblies to the Cabinet Rails
 - Installing Cage Nuts on the Front Rails
 - Attaching the Inner Races to the Chassis
 - Mounting the System on the Slides
 - Connecting and Routing the Power Cord(s)
 - Installing the Front Bezel
- Installing the Swing Arm Cable Management Bracket
- Installing the 2T-EXBAY Options

2.2 Unpacking the Shipment

The custom AlphaServer 4100 system shipment may include several cartons. Check the packing list to ensure that all items listed have been received.

If the equipment is damaged or if any items are missing, notify the delivery agent and contact the DIGITAL sales representative.

Save all shipping cartons in case the equipment needs to be moved to a new location, or needs to be returned for repair.

WARNING

The custom AlphaServer 4100 system can weigh up to 45.36 kg (100 lb). Use sufficient personnel or the proper lifting equipment to remove the system from the shipping carton.

2.3 Installing the Custom AlphaServer 4100 System

The following sections contain the procedure for installing the custom AlphaServer 4100 system in a 43U Rittal cabinet.

Tools Required

- Phillips-head screwdriver
- Flat-blade screwdriver
- Adjustable wrench

2.3.1 Assembling the Slide Assemblies

The slide assemblies are shipped with the slide brackets attached to the slides. Refer to Figure 2-1 and the following steps to remove the inner races from the right and left slide assemblies:

1. Find the right slide assembly ❶ that is shipped with the system.
2. Pull out the inner race ❷ until it locks. Press up on the locking lever ❹ (direction of the arrow ❸), and pull the inner race ❷ out of the right slide assembly ❶. Set the inner race aside.
3. Find the left slide assembly that is shipped with the system.
4. Pull out the inner race until it locks. Press up on the locking lever (direction of the arrow), and pull the inner race out of the left slide assembly. Set the inner race aside.

If the slide brackets are ever removed from the slide assemblies, refer to the following sections for the procedure for assembling the right and left slide assembly.

Caution

Using the specified slide bracket part number for the left and right slide assemblies is critical.

2.3.1.1 Assembling the Right Slide Assembly

Refer to Figure 2-1 and assemble the right slide assembly as follows:

1. Find the right slide assembly ❶ that is shipped with the system.
2. Pull out the inner race ❷ until it locks. Do not remove the inner race from the slide assembly at this time.
3. Orient the slide so that the arrow ❸ next to the locking lever ❹ is pointing upward.
4. Slide the RF/RR slide bracket ❺ (P/N 74-53082-01) onto the rear end of the right slide assembly ❶.
5. Attach the right rear slide bracket ❺ to the right slide assembly ❶ using the mounting holes shown in Figure 2-1 and two 8-32 screws ❻, flat washers ❼, lock washers ❸, and nuts ❾, but *do not* tighten. The right rear slide bracket must be loose enough to adjust later.
6. Press up on the locking lever ❹ (direction of the arrow ❸), and pull the inner race ❷ out of the right slide assembly ❶. Set the inner race aside.
7. Slide the RF/RR slide bracket ❿ (P/N 74-53082-01) onto the front end of the right slide assembly ❶.

8. Pull out the inside slide ① about halfway, enough to align two half-inch access holes on the inside slide with the mounting holes ② on the slide assembly and the front slide bracket ⑩. The first hole on the front end of the right slide assembly aligns with the first hole on the right front slide bracket as shown in Figure 2-1.
9. Attach the right front slide bracket ⑩ to the right slide assembly ① using the mounting holes shown in Figure 2-1 and two 8-32 screws ⑥, flat washers ⑦, lock washers ⑧, and nuts ⑨. Tighten these two screws and nuts.
10. Set this assembly aside.

Figure 2-1 Attaching the Slide Brackets to the Slide Assemblies

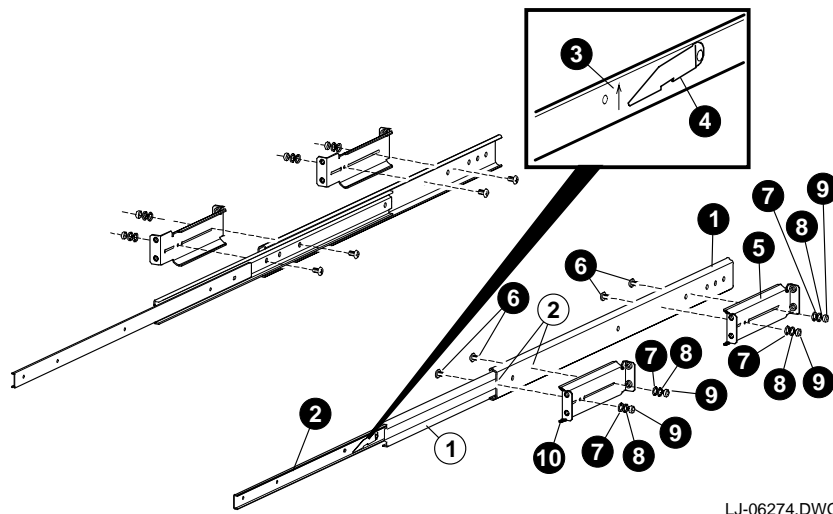

LJ-06274.DWG

2.3.1.2 Assembling the Left Slide Assembly

Refer to Figure 2-1 and assemble the left slide assembly as follows:

1. Find the left slide assembly that is shipped with the system.
2. Pull out the inner race until it locks. Do not remove the inner race from the slide assembly at this time.
3. Orient the slide so that the arrow next to the locking lever is pointing upward.
4. Slide the LF/LR slide bracket (P/N 74-53081-01) onto the rear end of the left slide assembly.
5. Attach the left rear slide bracket to the left slide assembly using the mounting holes shown in Figure 2-1 and two 8-32 screws, flat washers, lock washers, and nuts, but *do not* tighten. The right rear slide bracket must be loose enough to adjust later.
6. Press up on the locking lever (direction of the arrow), and pull the inner race out of the left slide assembly. Set the inner race aside.
7. Slide the LF/LR slide bracket (P/N 74-53081-01) onto the front end of the left slide assembly.
8. Pull out the inside slide about halfway, enough to align two half-inch access holes on the inside slide with the mounting holes on the slide assembly and the front slide bracket. The first hole on the front end of the left slide assembly aligns with the first hole on the left front slide bracket as shown in Figure 2-1.

Installation

- Attach the left front slide bracket to the left slide assembly using the mounting holes shown in Figure 2-1 and two 8-32 screws, flat washers, lock washers, and nuts. Tighten these two screws and nuts.
- Set this assembly aside.

2.3.2 Determining the Installation Area

The custom AlphaServer 4100 system requires 22.23 cm (8.75 in.) of vertical space or 15 contiguous holes in a 43U Rittal cabinet.

To determine the installation area, perform the following steps at the front and the rear cabinet rails. Refer to Figure 2-2 for a diagram of the installation area as seen from the front of the cabinet. Refer to Figure 2-3 for a diagram of the installation area as seen from the rear of the cabinet.

- Select a section of the cabinet rail where there is an indentation beside a hole and make a mark above this hole. This is the *starting point* of the installation area.
- Count up or down 15 holes from the starting point and make a mark above or below the 15th hole. The area between these two marks is the *installation area*. The bottom hole of the installation area is identified as hole 1 of the installation area.
- Repeat steps 1 and 2 for the same holes on the front of both front rails and the rear of both rear rails.

The total installation area for the custom Alpha Server 4100 system is or 22.23 cm (8.75 in.) of vertical space.

Figure 2-2 Installation Area and Rail-Hole Pattern (Front View)

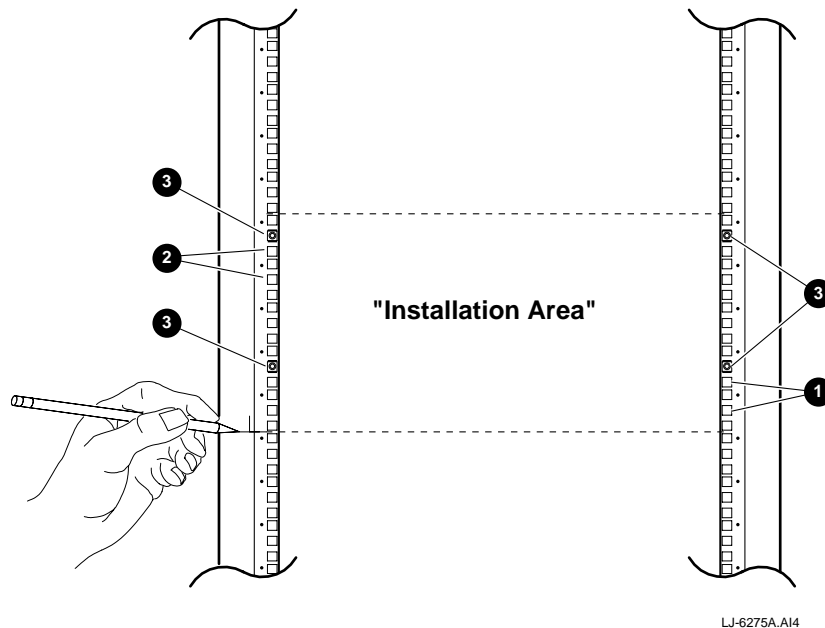

- ❶ Holes 2 and 4 for attaching right slide bracket.
- ❷ Holes 11 and 13 for attaching left slide bracket.
- ❸ Holes 5 and 14 for cage nuts used to secure system to left and right front rails.

Figure 2-3 Installation Area and Rail Hole Pattern (Rear View)

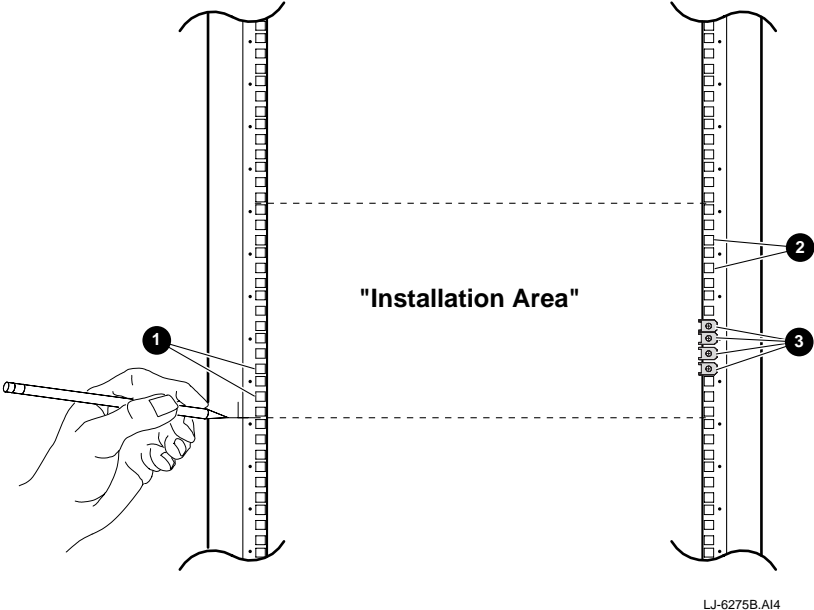

- ❶ Holes 2 and 4 for attaching right slide bracket.
- ❷ Holes 11 and 13 for attaching left slide bracket.
- ❸ Holes 4, 5, 6, and 7 for U-nuts used to secure swing arm cable management bracket to left rear rail.

2.3.3 Attaching the Slide Assemblies to the Cabinet Rails

The following sections contain the procedures for attaching the right and left slide assemblies to the cabinet rails.

2.3.3.1 Attaching the Right Slide Assembly to the Cabinet Rails

To attach the right slide assembly to the cabinet rails, refer to Figure 2-4 and proceed as follows:

1. Determine the proper mounting holes for the right slide brackets.
The proper mounting holes are the 2nd and 4th holes of the installation area (see Figure 2-2 and Figure 2-3).
2. Locate the right slide assembly ❶.
3. Place the right front slide bracket on the inside of the right front rail and align the two slide bracket holes with the 2nd and 4th holes of the installation area on the right front rail.
4. Install two M6 x 1.5 mm screws ❷ in the 2nd and 4th holes of the installation area to secure the right front slide bracket to the right front rail, but *do not* tighten.
5. Place the right rear slide bracket on the inside of the right rear rail and align the two slide bracket holes with the 2nd and 4th holes of the installation area on the right rear rail.
6. Install two M6 x 1.5 mm screws ❸ in the 2nd and 4th holes of the installation area to secure the right rear slide bracket to the right rear rail, but *do not* tighten.
7. Tighten the two 8-32 screws and nuts that secure the right rear slide bracket to the right slide assembly (shown in Figure 2-1).

Figure 2-4 Attaching the Slide Assemblies to the Cabinet Rails

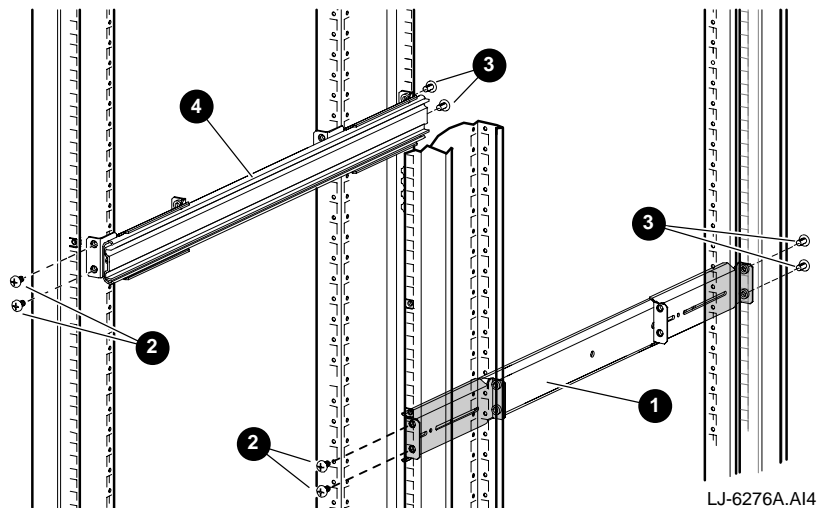

2.3.3.2 Attaching the Left Slide Assembly to the Cabinet Rails

To attach the left slide assembly to the cabinet rails, refer to Figure 2-4 and proceed as follows:

1. Determine the proper mounting holes for the left slide brackets.
The proper mounting holes are the 11th and 13th holes of the installation area (see Figure 2-2 and Figure 2-3).
2. Locate the left slide assembly ❹.
3. Place the left front slide bracket on the inside of the left front rail and align the two slide bracket holes with the 11th and 13th holes of the installation area on the left front rail.
4. Install two M6 x 1.5 mm screws ❷ in the 11th and 13th holes of the installation area to secure the left front slide bracket to the left front rail, but *do not* tighten.
5. Place the left rear slide bracket on the inside of the left rear rail and align the two slide bracket holes with the 11th and 13th holes of the installation area on the left rear rail.
6. Install two M6 x 1.5 mm screws ❸ in the 11th and 13th holes of the installation area to secure the left rear slide bracket to the left rear rail, but *do not* tighten.
7. Tighten the two 8-32 screws and nuts that secure the left rear slide bracket to the left slide assembly (shown in Figure 2-1).

2.3.4 Installing Cage Nuts on the Front Rails

Four cage nuts must be installed on the front cabinet rails to receive the thumb-screws on the front bezel that secure the system to the rails. Use the following procedure to install the cage nuts:

1. Locate the 5th and 14th holes of the installation area on the left and right front rails (see Figure 2-2).
2. Install a cage nut behind each mounting hole identified in step 1 by aligning it with the hole and snapping it into place. Ensure that the threads of the cage nuts are on the inside of the cabinet rails.

2.3.5 Attaching the Inner Races to the Chassis

To attach the inner slide races to the chassis, refer to Figure 2-5 and proceed as follows:

Caution

When performing this procedure, ensure that the arrow ❶ (shown in Figure 2-5) points upward and the locking lever ❷ points toward the front of the system. Otherwise, the slide will be damaged when the system is installed on the slide assemblies.

Attach the right inner slide race ❸ to the lower right side of the system chassis (as viewed from the front) using four 8-32 pan-head screws ❹.

Attach the left inner slide race ❺ to the upper left side of the system chassis (as viewed from the front) using four 8-32 pan-head screws ❹.

Figure 2-5 Attaching the Inner Slide Races

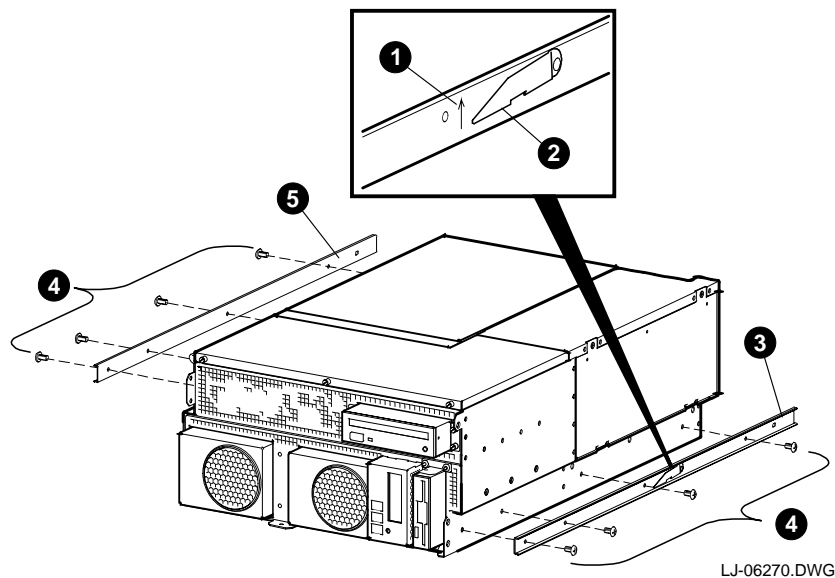

2.3.6 Mounting the System on the Slides

To mount the system on the slides, refer to Figure 2-6 and proceed as follows:

WARNING

The custom AlphaServer 4100 system can weigh up to 45.36 kg (100 lb). Use sufficient personnel or the proper lifting equipment when lifting or moving the system.

1. Pull both equipment slides **1** out fully to their locked positions.
2. Lift the chassis and position it so that the slide races **2** fit into the front end of the slides.
3. Push the system into the slides until it stops. Push up on the two locking levers **3** and then push the system into the cabinet.
4. Pull up on the front of the system and securely tighten all eight M6 x 1.5 mm screws that secure the slides to the cabinet rails.

Figure 2-6 Mounting the System on the Slides

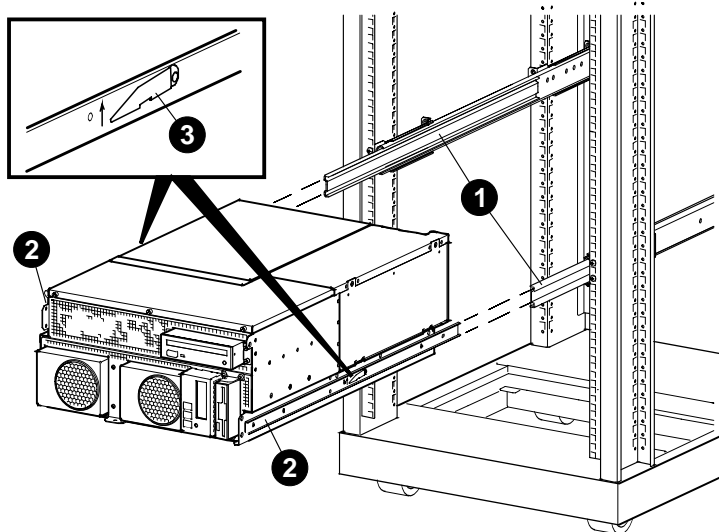

LJ-06271.DWG

2.3.7 Connecting and Routing the Power Cord(s)

To install the power cord(s), refer to Figure 2-7 and proceed as follows:

1. Attach the molded right angle power cord ❶ to the left power supply ac input receptacle ❷ located on the front of the chassis.
2. Route the power cord to the left and along the power cord tray ❸ located on the upper left side of the chassis.
3. Secure the power cord to the tray using tie wraps. Ensure that the tie wraps are positioned so that they allow the chassis to slide in and out of the cabinet without catching on the left front rail. Refer to Figure 2-10 to install the power cord strain relief on the rear of the chassis.

Note

At this time, leave the other end of the power cord disconnected from the cabinet power distribution unit. This connection serves as an ac power switch.

4. If the system has a second power supply installed, repeat steps 1 through 3 to connect and route the power cord that ships with the custom AlphaServer 4100 system for the right power supply.

Figure 2-7 Connecting and Routing the Power Cord(s)

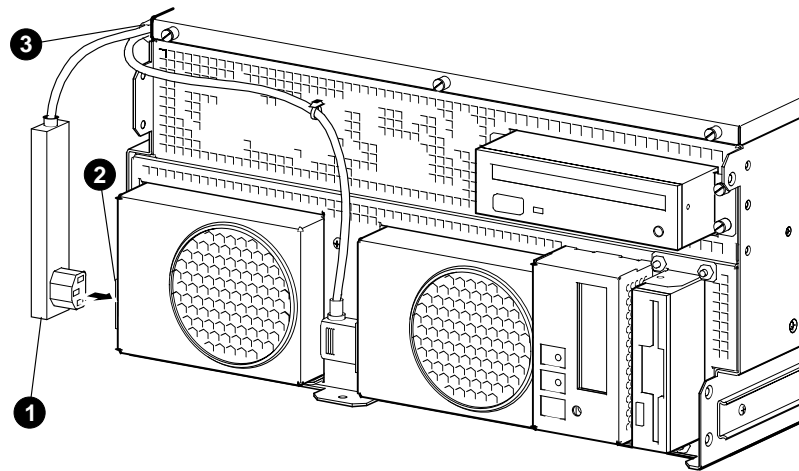

LJ-06269.DWG

2.3.8 Installing the Front Bezel

To install the front bezel, refer to Figure 2-8 and proceed as follows:

1. Pull the system partially out of the cabinet.
2. Attach the front bezel **1** to the top left bracket on the front of the system chassis using two 8-32 flat-head screws **2**.
3. Attach the front bezel **1** to the top right bracket on the front of the system chassis using one 8-32 flat-head screw **3**.
4. Attach the front bezel **1** to the bottom right bracket on the front of the system chassis using two 8-32 flat-head screws **4**.
5. Attach the front bezel **1** to the bottom bracket on the front of the system chassis using one 8-32 flat-head screw **5**.

Figure 2-8 Installing the Front Bezel

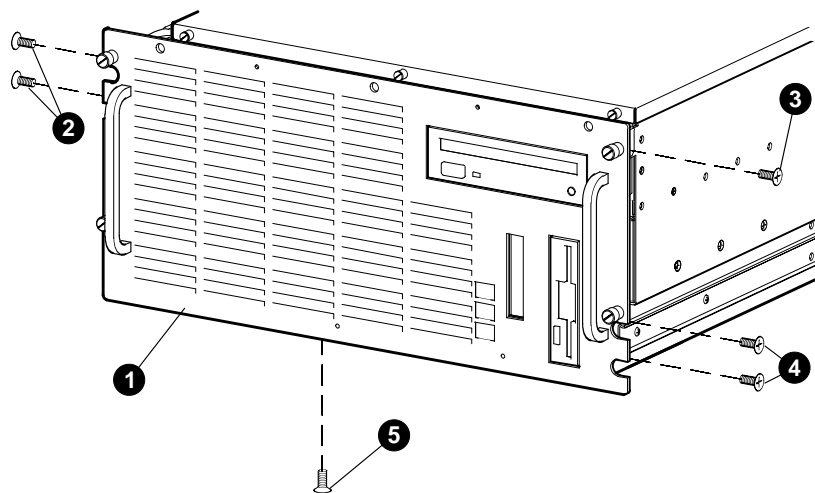

LJ-06273.DWG

Installation

After attaching the front bezel to the system chassis, push the system into the cabinet and secure the system to the front rails with the four thumb-screws ❶ on the front bezel (see Figure 2-9).

Figure 2-9 Securing the System to the Cabinet Rails

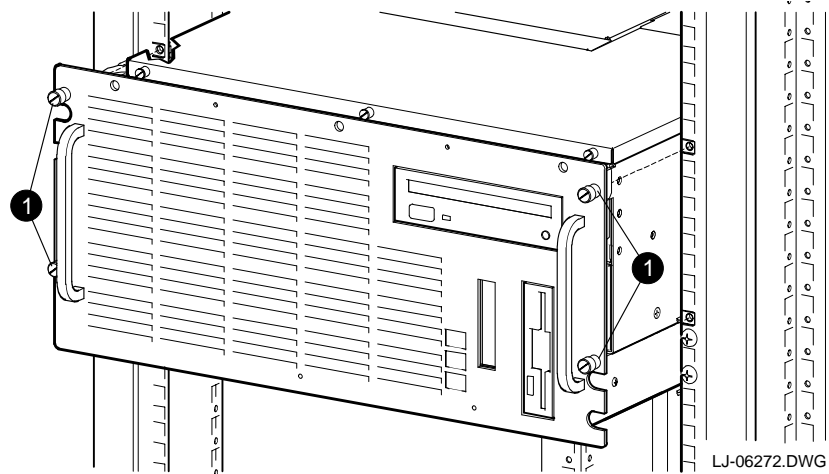

2.4 Installing the Swing Arm Cable Management Bracket

The cable management system consists of a swing arm cable management bracket and cable tie wraps. When installed, the swing arm cable management bracket keeps the data cables and power cord(s) in place to prevent them from being damaged when the system is pulled out or pushed into the cabinet.

To install the swing arm cable management bracket, refer to Figure 2-10 and proceed as follows:

1. Locate the 4th, 5th, 6th, and 7th holes of the installation area on the left rear cabinet rail (see Figure 2-3).
2. Install a U-nut ❶ over each hole identified in step 1 by sliding the U-nut over the edge of the cabinet rail and aligning it with the hole. Ensure that the threaded half of the U-nuts are toward the inside of the cabinet.
3. Attach the swing arm cable management bracket ❷ to the left rear cabinet rail using four 10-32 truss-head screws ❸.
4. Attach the strain relief ❹ for the power cord to the rear of the chassis.
5. The routing of cables to the swing arm cable management bracket is left to the customer's preference.

Figure 2-10 Installing the Swing Arm Cable Management Bracket

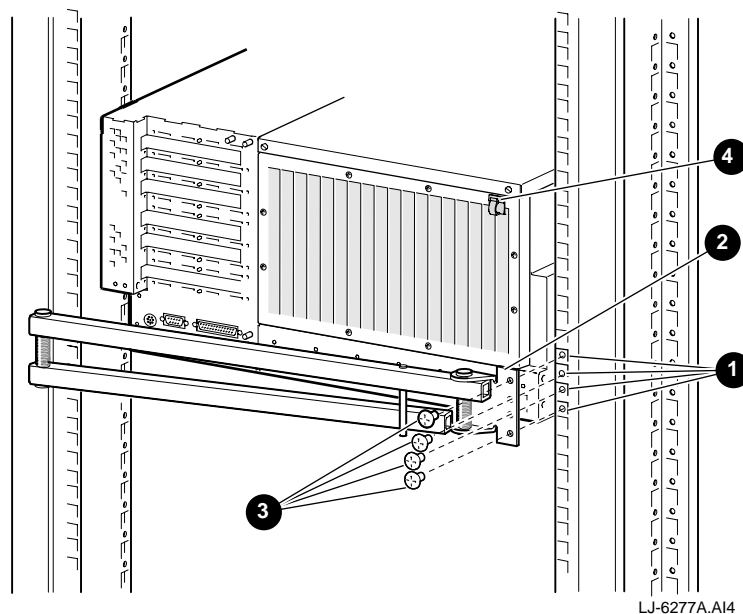

2.5 Installing the 2T-EXBAY Options

There are five 2T-EXBAY options that can also be installed in the Rittal cabinet. The five options along with their components are listed in Table 2-1.

Table 2-1 2T-EXBAY Options

Option	Components
2T-EXBAY-01	BA370 chassis Rackmount kit for BA370 Rittal mounting hardware HSZ70 controller Alpha host controller Cables
2T-EXBAY-02	BA370 chassis, expansion Rackmount kit for BA370 Rittal mounting hardware Cables
2T-EXBAY-03	HSZ70 controller Alpha software kit
2T-EXBAY-05	BA370 chassis Rackmount kit for BA370 Rittal mounting hardware HSZ70 controller Intel host controller Cables
2T-EXBAY-06	HSZ70 controller Intel software kit

To install the 2T-EXBAY options in a Rittal cabinet, refer to the MP-03775-01 print set drawing and the *DIGITAL StorageWorks Ultra SCSI RAID Enclosure (DS-BA370-Series) User's Guide* (EK-BA370-UG).

WARNING

The BA370 chassis weighs over 90.72 kg (200 lb). Use sufficient personnel or the proper lifting equipment when lifting or moving the chassis.
